

Model PC-1

Pump Cycling Controller



Automatically controls pump run-stop time to match the flow

SIStec

Model PC-1 Pump Cycling Controller

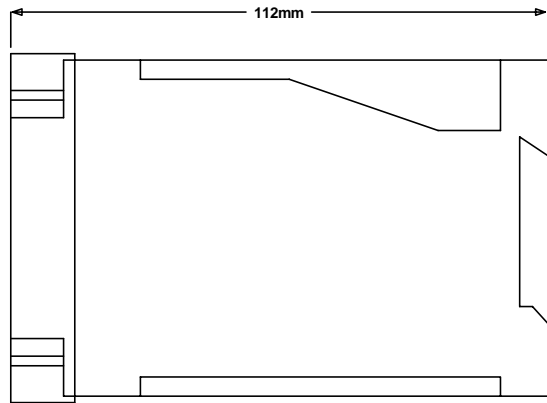
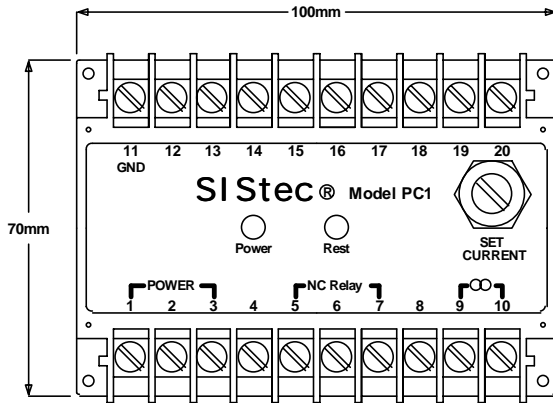

Using the motor current to determine the pump motor load, the Model PC-1 pump Cycling Controller, adjusts the on / off periods of the pump motor to match the flow rate. When the pump draws air, the motor is turned off. If the flow increases, the motor will run continuously if necessary.

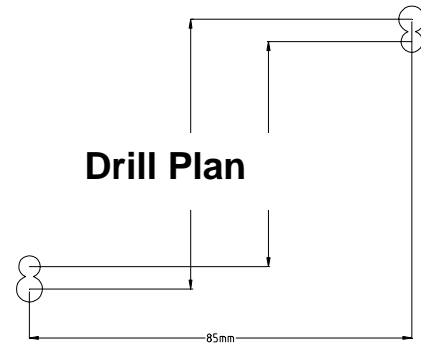

Supply	24Vac or 110Vac or 240Vac or 380Vac
Power	6VA
Relay Contacts	10A 250V
Input Current	1A
Operating Temperature	0 to 60 °C

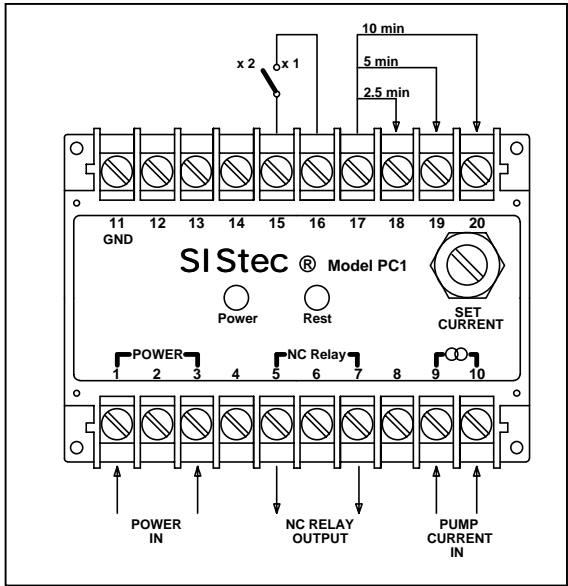

Distributed by

SIS tec
 PO Box 79
 Mount Hawthorn 6915